

Drainbox 300

Lifting stations for domestic applications



Applications

Domestic: detached homes, cottages, rural properties, second homes, etc.
Professional: Restaurants, small hotels, stores, workshops, small industries, etc.

Innovation

Drainbox is the advanced, specific solution created by ESPA for the evacuation of water, from any source (foul water, faecal water, rainwater ...) in all environments; domestic or professional, rural or urban, with complicated or unfavourable drainage conditions.

Drainbox collects, stores, treats and drives the water to the drainage level, offering a series of truly outstanding advantages in terms of versatility, installation and performance.

Drainbox is based on simple and highly effective drainage technology that enables each pumping kit to be customised with the type of pump that is most suitable for the function and services to be provided.

Drainbox is supplied with an innovative tank, and a design that includes a series of novel technical advantages that add up to multiple services that are accumulated for the purpose of customising each installation. Customers can select the input and output pipes, ventilation pipes, emergency evacuation system, retention valve, etc.

Maximum temperature of liquid: 35°C.

Model	Configuration	Size in mm	
		Outlets	
Drainbox 300			
Vigilex 600 MA	Complete with water level float switch	63	110
VigilexSS 1100M		63	110
Drainex 201 M/201T		63	110
Draincor 180M		63	110
Draincor 200T		63	110
Drainex	Coupling kit with guide rail	63	110
Draincor		63	110

Legend

- M:** Single phase
- A:** Complete with floatswitch
- TP:** Vertical outlet
- LT:** Horizontal outlet
- D:** Grinder pump
- KE:** lifting removal kit.

Single phase	Price	Three phase	Price	k/W	No. of pumps	Type	Tank capacity	Inlet in"
Drainbox 300 800 M A TP	577			0.5	1	Vigilex 600 M A	300 l	1¼"
Drainbox 300 900 M A TP	750			0.8	1	Vigilex SS 1100 M	300 l	1½"
Drainbox 300 1200 M A TP	830			1.1	1	Vigicor 150 M A	300 l	2"
Drainbox 300 1400 M TP KE	1,324	Drainbox 300 1400 TP KE	1,418	0.9	1	Drainex 201 M/T	300 l	1¼"
Drainbox 300 1600 MD TP KE	1,619			1.1	1	Draincor 180 M	300 l	2"
		Drainbox 300 1800 D TP KE	1,605	1.25	1	Draincor 200 T	300 l	2"

Lifting stations for domestic applications

Drainbox 600

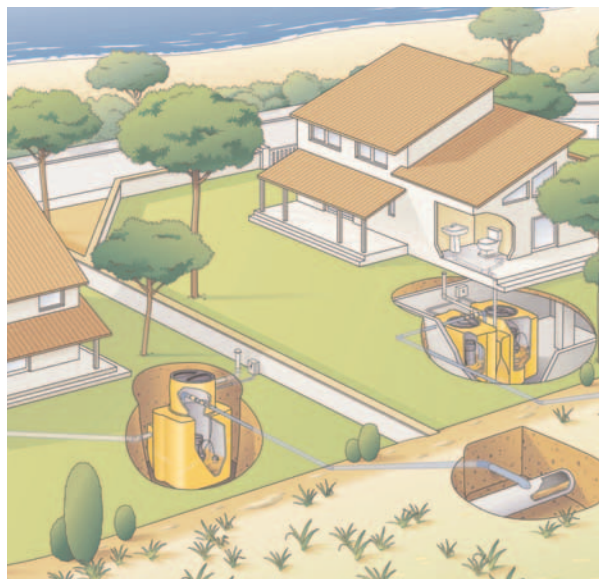

Drainbox 600		Size in mm	
		Outlets	
VigilexSS 1100M	Complete with water level float switch	63	110
Vigicor 150M		63	110
Drainex 201 M/201T		63	110
Draincor 180M		63	110
Draincor 200T		63	110
Drainex	Coupling kit with guide rail	63	110
Draincor		63	110

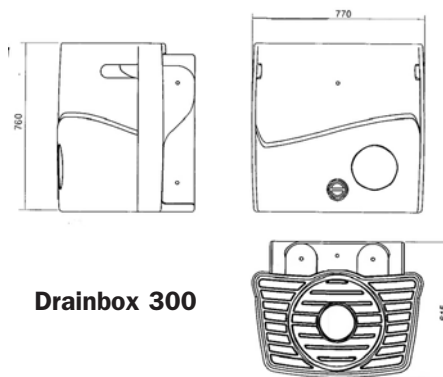

Drainbox 300

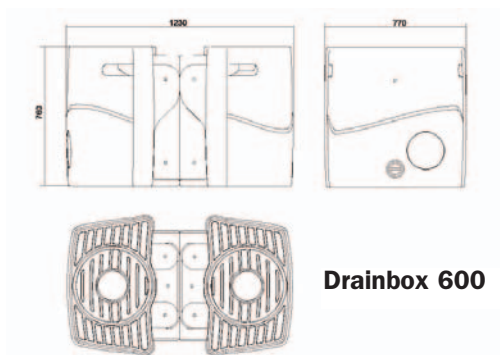

Drainbox 600



Single phase	Price	Three phase	Price	k/W	No. of pumps	Type	Tank capacity	Inlet in"
Drainbox 600 900 M TP	2,314			0.8	2	Vigilex SS 1100 M	600 l	1½"
Drainbox 600 1200 M D TP	2,527			1.1	2	Vigicor 150 M	600 l	2"
Drainbox 600 1400 M TP KE	2,783	Drainbox 600 1400 TP KE	2,741	0.9	2	Drainex 201 M/T	600 l	1¼"
Drainbox 600 1600 M TP KE	3,357			1.1	2	Draincor 180 M	600 l	2"
		Drainbox 600 1800 D TP KE	3,102	1.25	2	Draincor 200 T	600 l	2"

Drainbox 750/1000/ 1250/1500

Larger lifting/
sewage stations

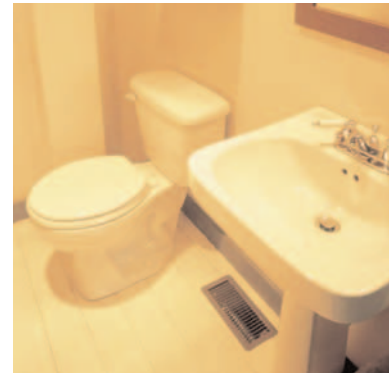

Applications

Private housing, industry, commercial premises, leisure complex, hotel/motel/motorway services and single households.

Each pump chamber is made up of strong, medium density polyethylene.

All packages come complete with pipework pre-assembled in the chamber, standard pedestrian access cover and frame, ready for installation into the ground, after which the pumps and control equipment are added.

All dual pump sets are supplied with controls for fully automatic operation and a high level alarm indicator.

Chambers are available in several different sizes.



+ BS EN 12050-1: 2001

+ BS EN 12056-4: 2000

+ BS EN 752-6: 1998



Pre-cast tanks available on request.

Larger lifting/ sewage stations

Drainbox 750/1000/1250/1500

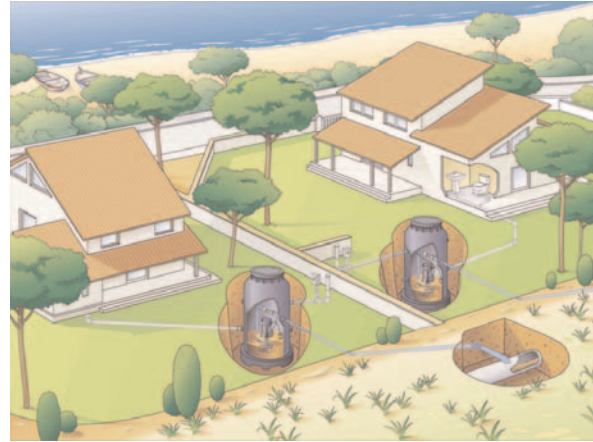
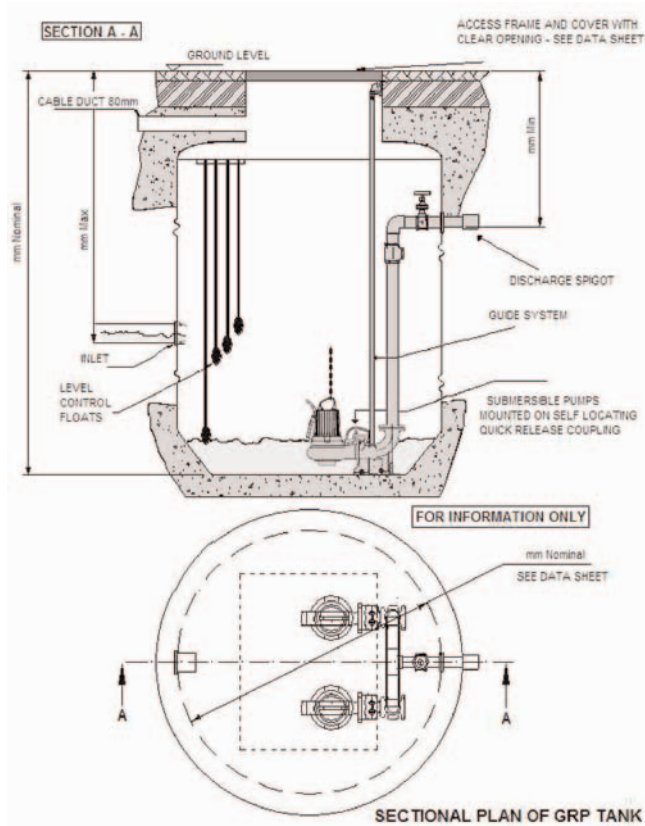

Single phase	Three phase	Price	Pumps	Outlet	Chamber size	Pump installation
Drainbox 750FS	Drainbox 750FS	1,115	1	50/65mm	750 X 1200mm	FREE STANDING
Drainbox 1000FS	Drainbox 1000FS	1,471	1	65mm	1000 X 1500mm	FREE STANDING
Drainbox 1000GR	Drainbox 1000GR	2,725	2	65mm	1000 X 1500mm	GUIDE RAIL
Drainbox 1250GR	Drainbox 1250GR	3,388	2	65mm	1250 X 2000mm	GUIDE RAIL
Drainbox 1500GR	Drainbox 1500GR	4,024	2	65mm	1500 X 2500mm	GUIDE RAIL

Please select which Drainex pump(s) from pages 28 to 30 and add their price to the above chamber price.

Heavy access covers on request.

Pumps can be with vortex impeller or grinder.

Other options are available on request.

Please add £136 for 65mm internal fittings for Drainex 750 FS.

All twin pump sets come c/w control panel.

Applications

Drainbox 750P	Drainbox 750P	Annexe or one bedroom conversion
Drainbox 1000P	Drainbox 1000P	Three bedroom house
Drainbox 1000G	Drainbox 1000G	Three bedroom house
Drainbox 1250G	Drainbox 1250G	Five bedroom house, small office units/industrial/small hotels/nursing homes
Drainbox 1500G	Drainbox 1500G	Large commercial/multi dwellings/hotels/hospitals/sewage works