

# Submersible grinder pumps

# Draincor

## Applications

Grinder pump for sewage water with filaments.

## Materials

### Pump Body

Cast iron.

### Impeller

Cast iron.

### Grinder System

Steel F-520.

### Detachable Pump Base

Stainless steel AISI 304.

### Mechanical Seal

Silicon Carbide and graphite.  
O'rings in NBR.

## Motor

Class F insulation.  
IP 68 Protection.  
Continuous operation.  
Maximum temperature of liquid: 40°C.

## Equipment

1½" BSP Female threaded discharge elbow.  
Single phase supplied with capacitor box.  
**Draincor M A:** Complete with float switch.

## Options

Guide rail kit DR1.

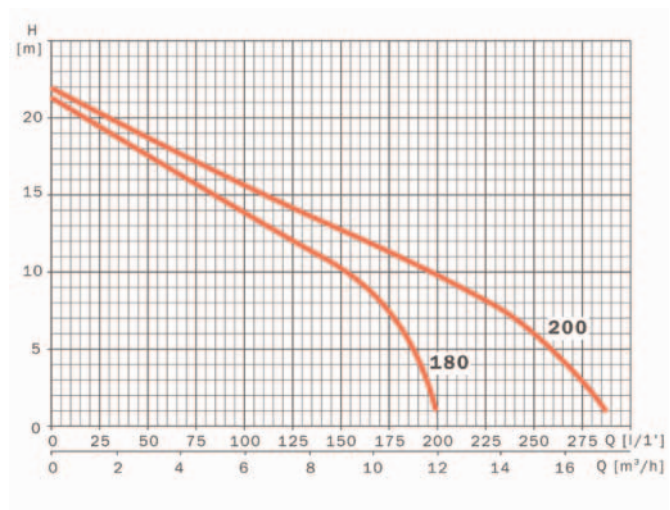

Draincor 200 now obsolete



MODEL	A	P1 (kW)		kW	HP	µF
	1~ 230 V	1~	3~			
<b>Draincor 180</b>	7.8	1.7	-	1.1	1.5	16

# Draincor 180/200

## Submersible grinder pumps

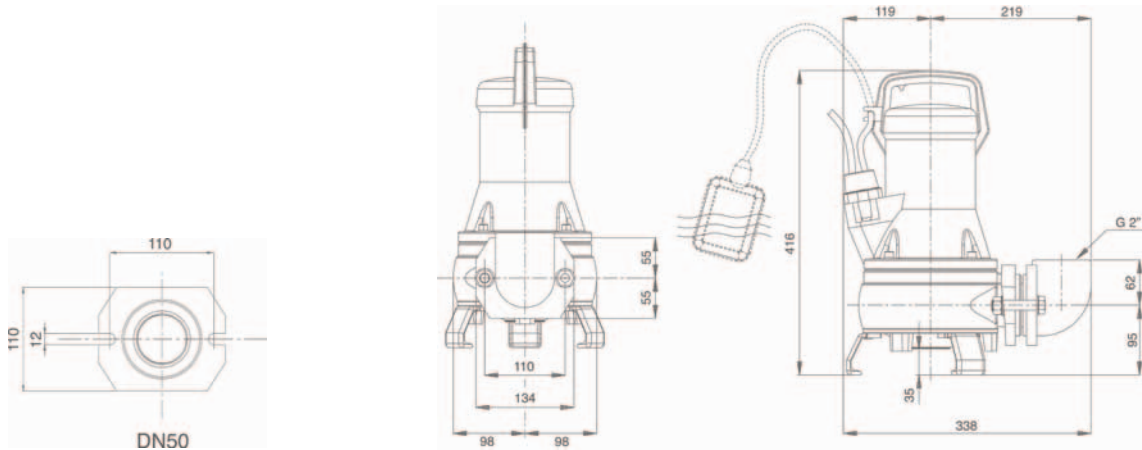

Single phase	Price	Three phase	Price	I/1'	25	50	100	150	175	200	250	290
				m <sup>3</sup> /h	1.5	3	6.0	9.0	10.5	12.0	15	17.4
Draincor 180 M	<b>846</b>			H	18.0	16.7	13.7	10.0	7.0	-	-	-
Draincor 180 M A	<b>872</b>			[m]								

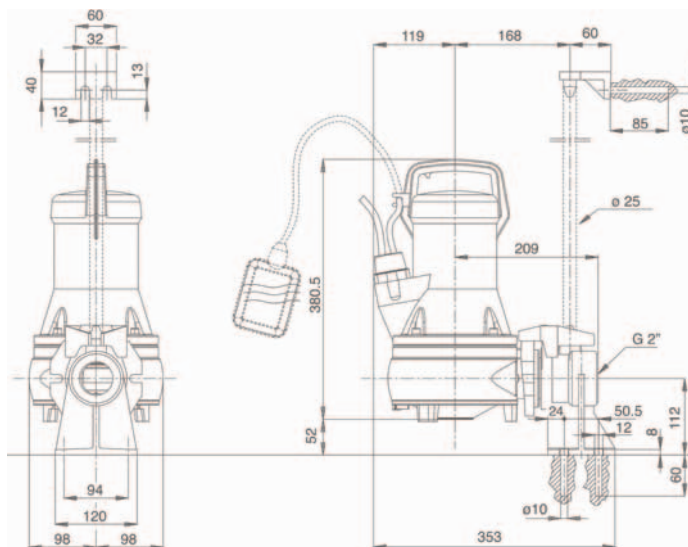

**DR1 Kit**

Rapid pump removal and installation kit using single guide rail. (2" rail to be obtained by installer)	<b>Kit DR1 Draincor</b>	<b>Price</b>
		<b>50</b>