

Fin

Pump without pre-filter



Applications

Specially designed for high flow water supplies and recycling of treated and soluble water.

Materials

Pump Body

Polypropylene.

Impeller

Glass loaded polymer.

Diffuser

Polypropylene.

Motor Shaft

Stainless steel AISI 420.

Mechanical Seal

Graphite and alumine.

Motor

Class F insulation.

IP55 Protection.

Continuous operation.

Single phase with built-in thermal protection.

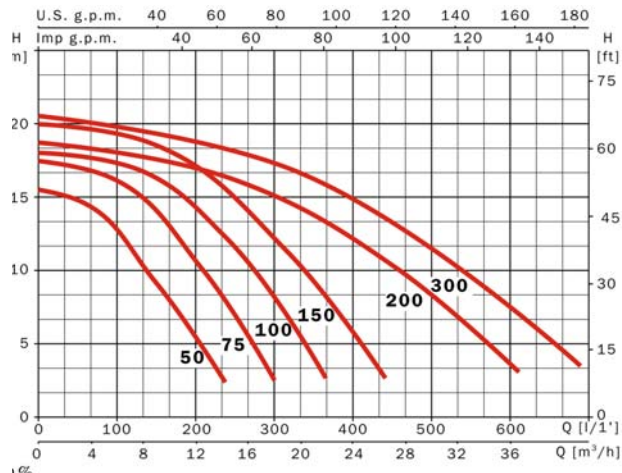

+ Sea water

+ Fin + Pre-filter = Flipper 2N

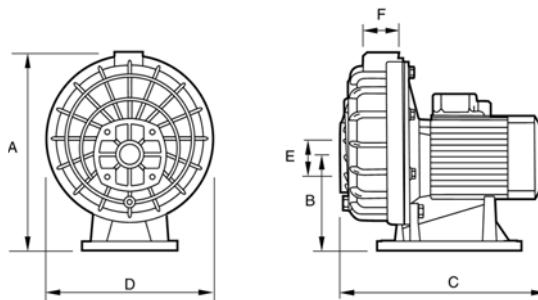

	A	B	C	D	E	F	Kg
Fin 50	351	170	364	296	2"	2"	10.5
Fin 75	351	170	364	296	2"	2"	11.5
Fin 100	351	170	364	296	2"	2"	12
Fin 150	351	170	384	296	2"	2"	15
Fin 200	351	170	411	296	2"	2"	17.5
Fin 300	351	170	411	296	2"	2"	18.5

Single and Three phase	Price	A			P1 (kW)		kW	HP	µF	l/1'	100	133	183	233	283	333	383	433
		1~ 230V	3~ 230V	3~ 400V	1~	3~												
Fin 50M & T	248	3.7	2.7	1.6	0.8	0.8	0.37	0.50	16		12	10	6.8	2.8				
Fin 75M & T	257	5	3.4	2	1.1	1.1	0.55	0.75	16		16	14	11.5	8.4	4			
Fin 100M & T	262	6.3	4.3	2.5	1.4	1.3	0.75	1	16		17	16.8	15	12.5	9.4	5.3		
Fin 150M & T	295	7.3	4.8	2.8	1.6	1.6	1.1	1.5	25		19.4	19	17.7	15.7	13	10.3	7	3
										l/1'	233	300	367	433	500	567	633	700
										m³/h	14	18	22	26	30	34	38	42
Fin 200M & T	335	8.8	6	3.5	1.9	1.8	1.5	2	30		16.6	15.2	13.3	11	8	5		
Fin 300T	357		6.8	4			2.3	2.2	3		18.5	17.4	16	14	11.8	9	6	3