

SANIRELEV 11 AND 22

LIFT STATIONS



SANIRELEV 11



SANIRELEV 22



Lift stations for foul waters for domestic use and sewage in three versions:

- **SANIRELEV 11 SR 10T**

Tank set-up for a DW range electric pump (with single channel impeller) and DW VOX (with vortex impeller), with 2" discharge pipe, without coupling foot and lowering device

- **SANIRELEV 11 SR 10 PT**

Tank set-up for a DW range electric pump (with single channel impeller) and DW VOX (with vortex impeller), with 2" discharge pipe, coupling foot and lowering device

- **SANIRELEV 22 SR 20 PT**

Tank set-up for two DW range electric pumps (with single channel impeller) and DW VOX (with vortex impeller), with 2" discharge pipe, with coupling feet and lowering devices

TECHNICAL DETAILS

- Strong construction
- Easy installation

TECHNICAL DATA

Reservoir

- Large watertight cover with gasket for easy intervention
- Reservoir capacity: 360 litres (SANIRELEV 11 SR 10T and SANIRELEV 11 SR 10 PT), 540 litres (SANIRELEV 22 SR 20 PT)
- Reservoir weight: 30 kg (SANIRELEV 11 SR 10T and SANIRELEV 11 SR 10 PT), 44 kg (SANIRELEV 22 SR 20 PT)
- DN 100 inlet
- DN 50/63 outlet
- Can be buried

Electric pump (to be inserted in the three models prepared)

- DW electric pump (with single channel impeller) or DW VOX (with vortex impeller) completely in AISI 304 stainless steel
- 2800 min-1
- 230V +/- 10% single phase voltage; 400V +/- 10% three-phase voltage
- Class of insulation F
- IPX8 Protection rating
- Maximum temperature of the liquid pumped: 40°C
- Max. solids size for passage: 50 mm

MATERIALS

Reservoir

- Polyethylene reservoir
- PVC inlet and outlet pipes

Electric pump (to be inserted in the three models prepared)

- Completely in AISI 304 stainless steel
- Equipped with twin mechanical seal: SiC/SiC/NBR (pump side) Carbon/Ceramic/NBR (motor side) with interposed oil chamber

For technical data regarding the DW electric pumps (with single channel impeller) or DW VOX (with vortex impeller) see page 16

ACCESSORIES (on request)

- Kit for SANIRELEV SR 11-22 including 1 shut-off valve, 1 non-return ball valve and 2 fittings

For other accessories see 66

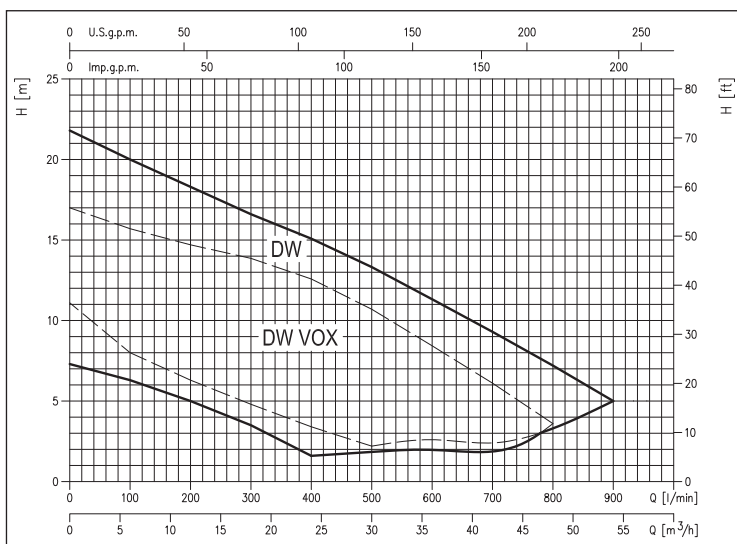

TECHNICAL SPECIFICATIONS

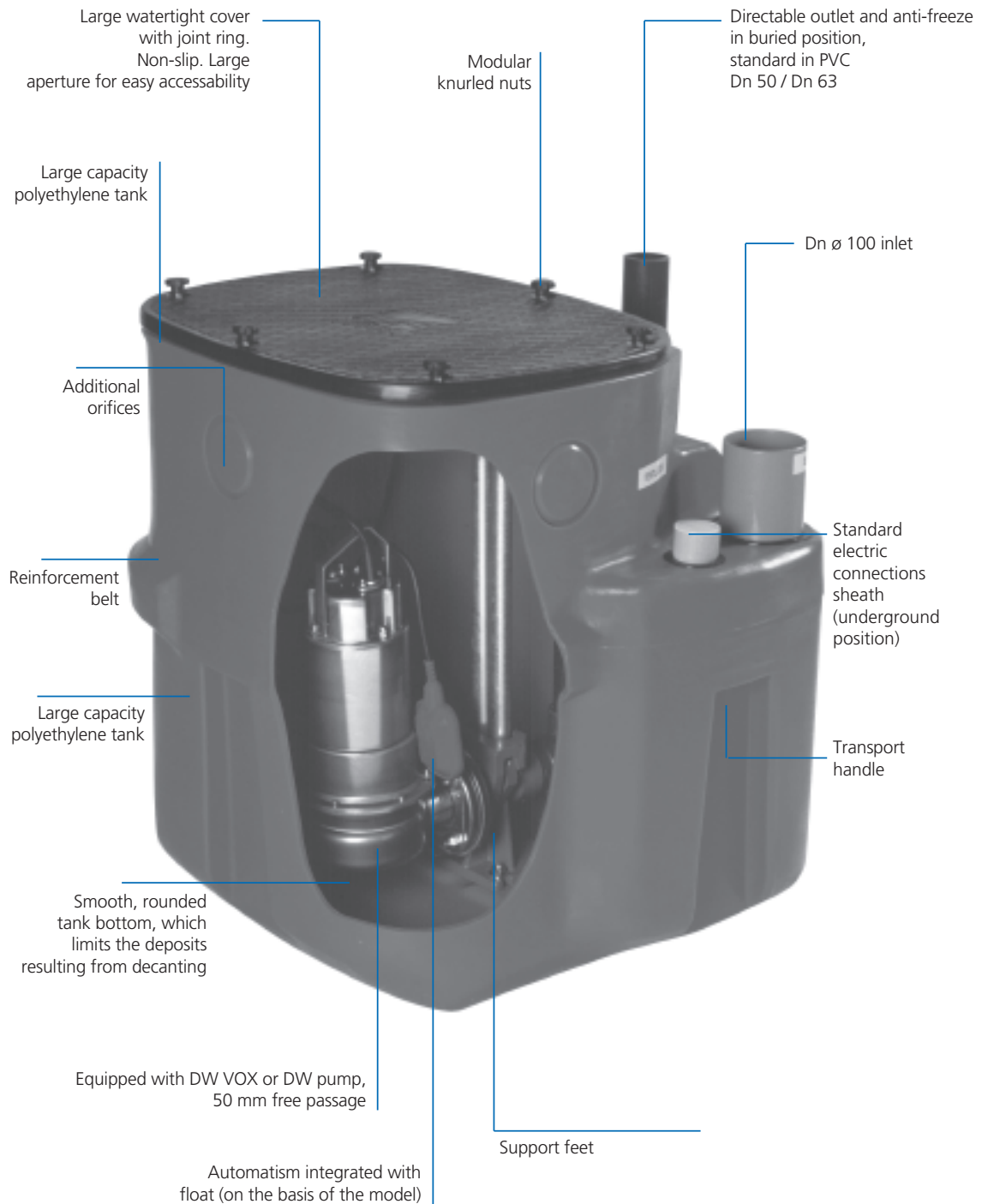

TECHNICAL SPECIFICATIONS

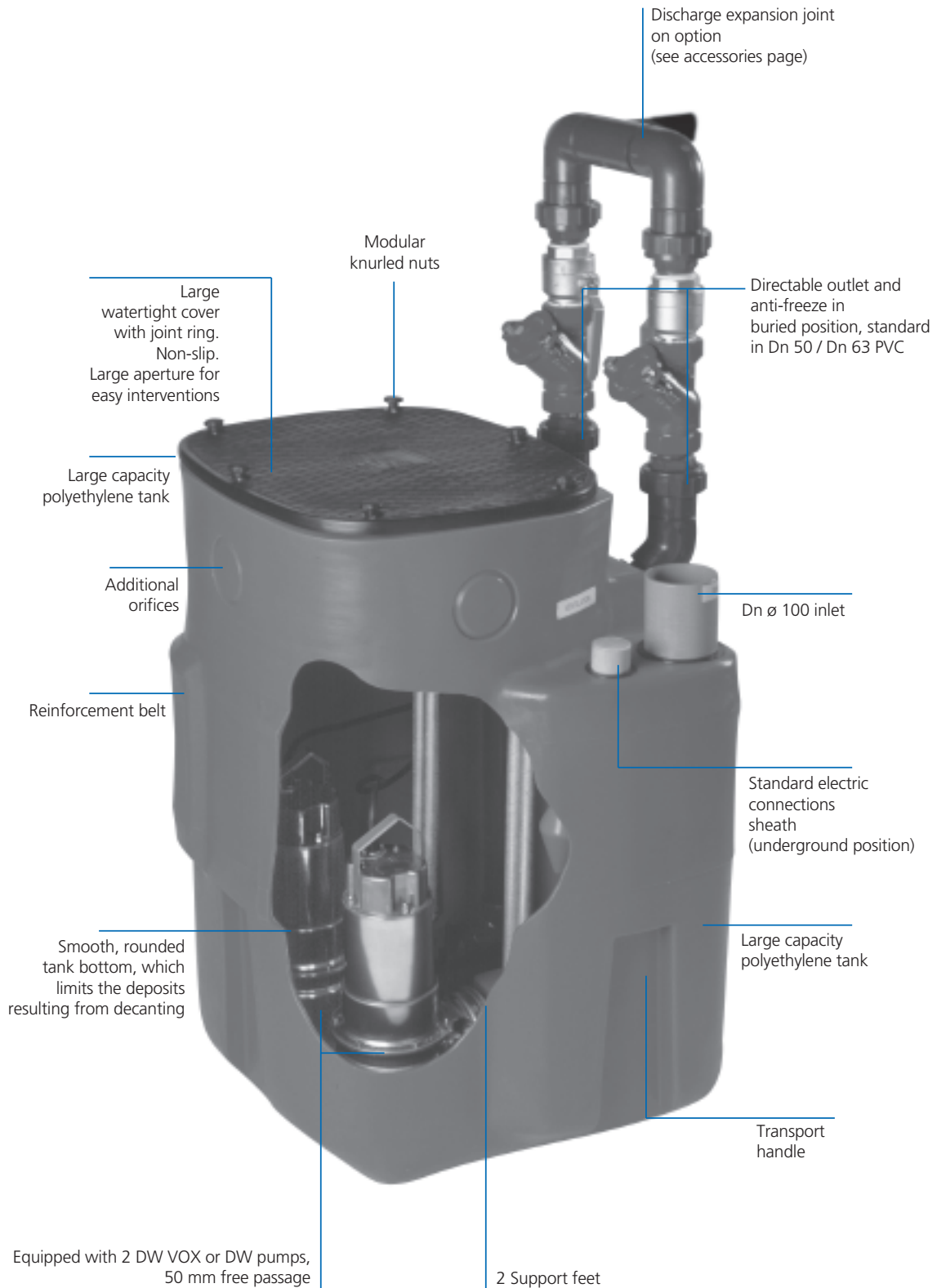

LIFT STATIONS

SANIRELEV 11 SR 10T DIMENSIONS WITHOUT COUPLING FOOT

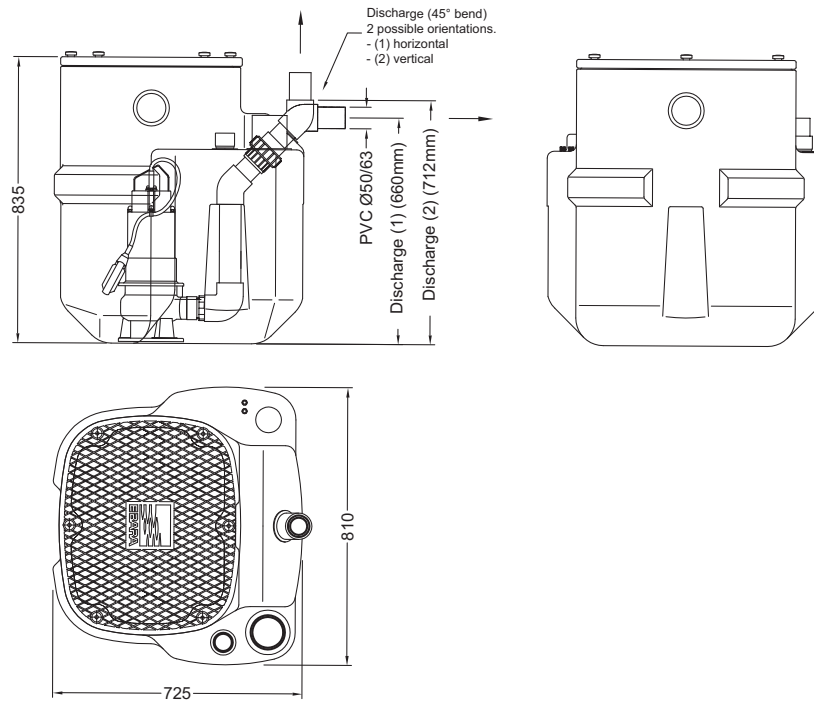

SANIRELEV 11 SR 10 PT DIMENSIONS WITH COUPLING FOOT

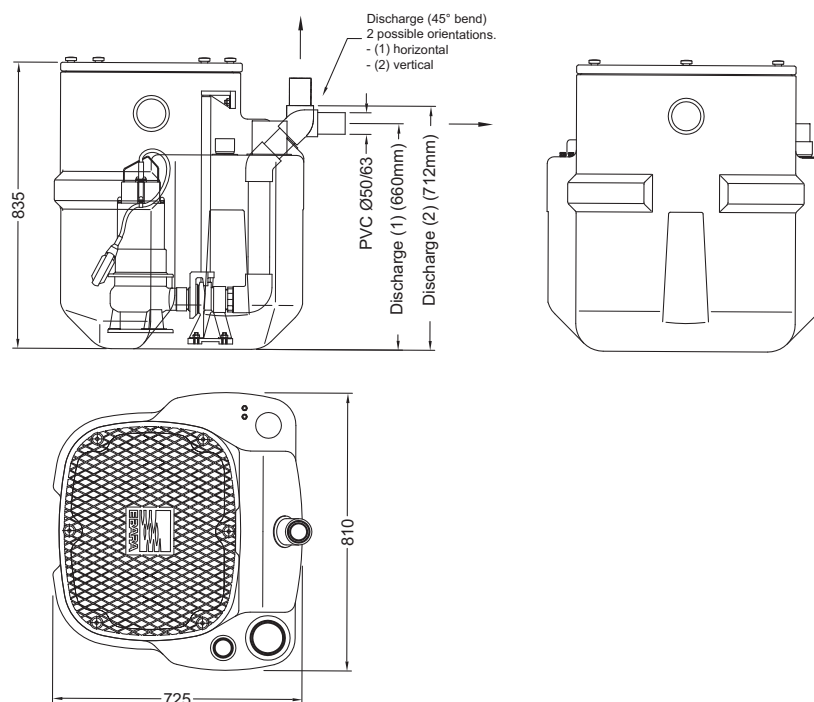

LIFT STATIONS

SANIRELEV 22 SR 20 PT DIMENSIONS WITH 2 COUPLING FEET

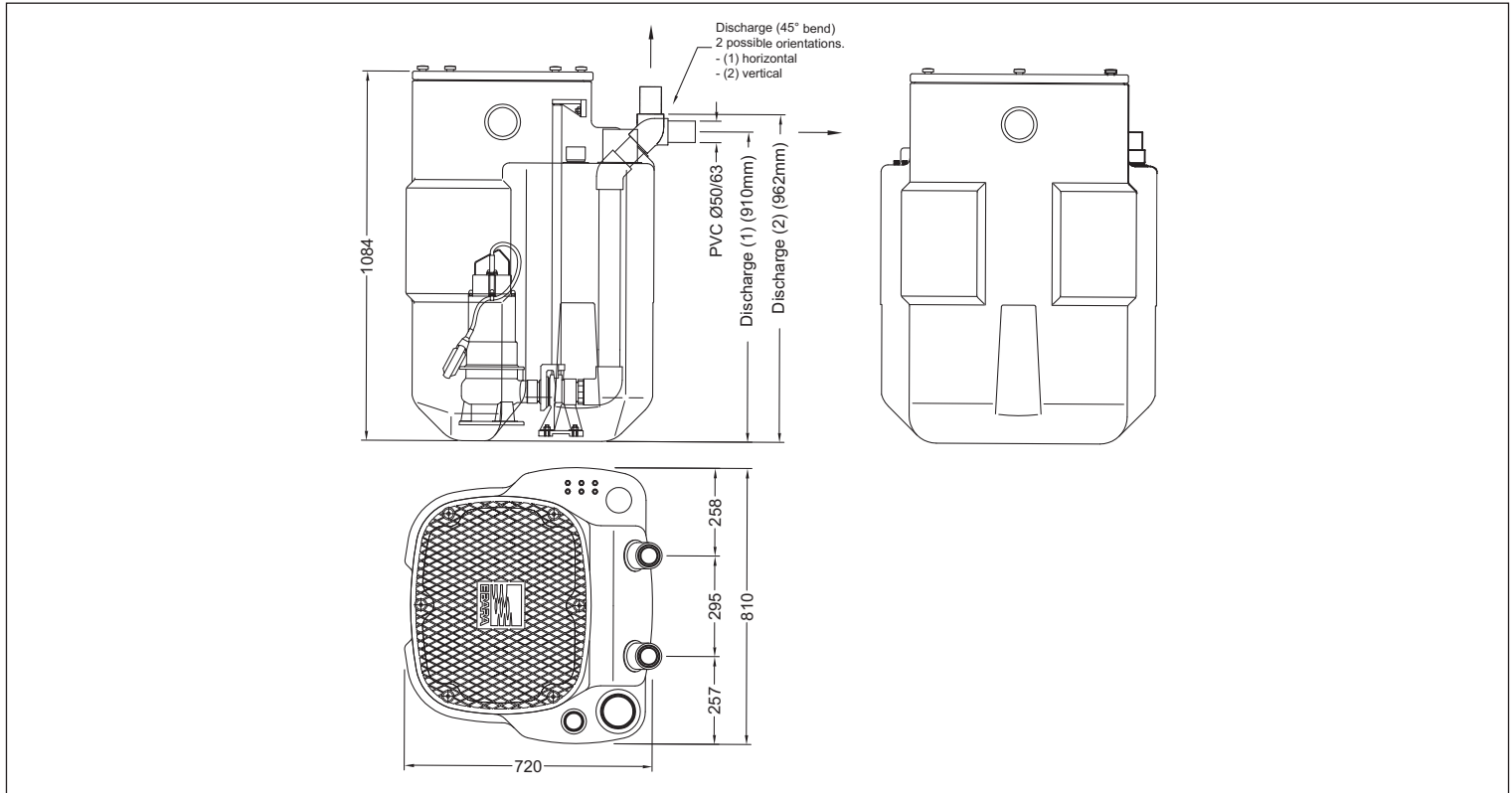

UNDERGROUND INSTALLATION

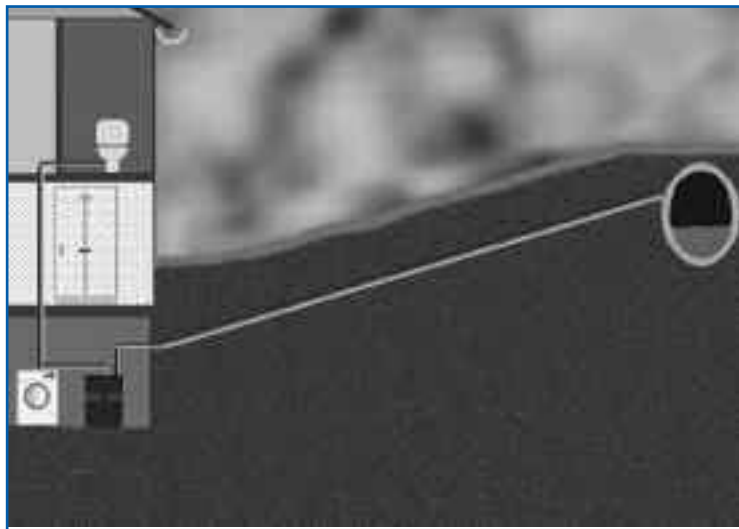

BURIED INSTALLATION

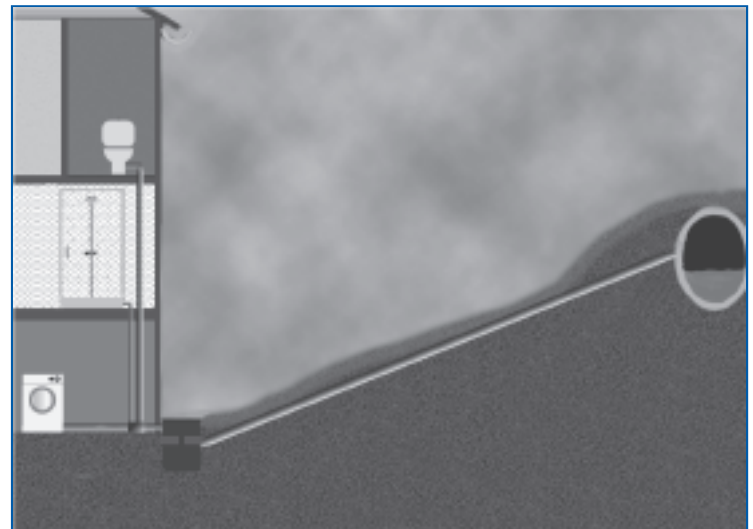

The EBARA lift stations and pumps are selected depending on 3 essential criteria:

1. The nature of the waters to lift (irrigation waters, domestic sewage, small-scale water collection, restaurant waters, clinical, laboratory, public WC, etc.)
2. The flow rate calculated on the basis of 200 l/user and per day, considering a coincidence coefficient.
3. The manometric head HMT (Difference in level + pressure drop in the pipe, different valves and bends).

Pump flow rate calculation:

Q_p (peak time flow rate in m^3/h): $Q_p \text{ m}^3/h = N^{\circ} \text{ users} \times 0,2 \times 3$

$$Q_p \text{ m}^3/h = \frac{Nb \text{ usag.} \times 0,2 \times 3}{8}$$

Pressure drop in the pipes (50 or 65 internal (PVC) and selection of recommended discharge pipe.

Considering that the smallest pump will have a flow rate of more or less 5 m^3/h to make things easier we have considered 4 flow rates: 5, 10, 20 and 30 m^3/h corresponding to 65, 130, 260 and 390 users and 5 pipe lengths 25, 50, 100 and 200 m. Over 200, we must be consulted.

CALCULATION EXAMPLE

Installation for 10 persons. Waters to lift. all types of water (WC, kitchen...)

Difference in level: 4 m (from the bottom of the tank to the highest flow point) Discharge length: 180 m

Current: single-phase 230 V

Station positioning: underground

$$Q_p \text{ [m}^3/h] = \frac{10 \times 0,2 \times 3}{8} = 0,75 \text{ [m}^3/h]$$

Loss of load: about 1.5 m (in a pipe-50)

Considering a lift length of 4 m + 1,5 m = 5,5 m

Model recommended:

Pump station:

- Sanirelev 11 SR 10 PT
- Sanirelev 11 SR 10 T

NB: the pump supplied with this station is a DW VOX Mono, motor power: 0.75 kW

SOME ADVICE FOR INSTALLATION

Installation of the tank

1. Underground: find an accessible place.

Nor being subject to corrosion, the EBARA pumps can be placed without any particular precautionary measures.

2. Underground tanks: (SR 11, SR 22)

- The tank must rest on a bed of sand.
- The cover can be easily accessed for maintenance.
- Filling must be performed with sand and in no case with stones or gravel.

Important: the tank must not be positioned in a passage place. Do not walk or circulate over the cover. The warranty does not cover the damage consequent to the failure to comply with this rule. If the tank must be buried deeply, it is recommended to use reinforced cement walls. In this case, manholes can be placed on the wall, as used on carriageways or footpaths.

TAPS AND FITTINGS: VALVES

They are envisioned as options. The valve prevents the return of effluent into the tank when the pump stops. Consequently, this valve must be used beyond 4-5m of discharge.

The valve allows isolation of the station if necessary.

The stations with 2 SR 22 pumps can be mounted with 2 separate flow columns or with expansion JOINT with valves.

In the case of underground stations with elevation, an independent valve opening can be supplied, in order to make the entire discharge pipe freeze-proof.

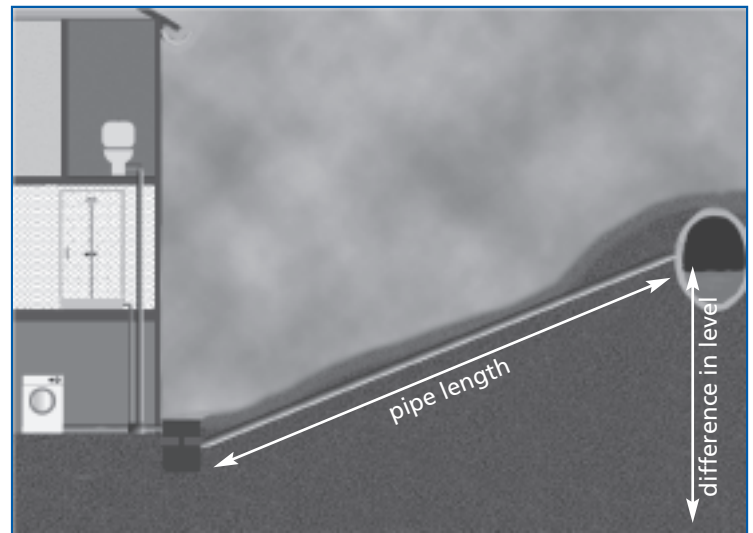

Number of users	Equivalent power in m^3/h	Pressure drop in m, on the basis of the length of the pipe and its diameter. in a long pipe:			
		25 m	50 m	100 m	200 m
from 0 to 65	5	0,2	0,4	0,8	1,5
from 66 to 130	10	1,3	2,5 o 1,0	5,0 o 2,0	4,0
from 131 to 260	20	5,0 o 1,5	3,0	6,0	12,0
from 261 to 390	30	6,0	6,0	12,0	consult us

Pressure drop in a pipe: in blue \varnothing 50 mm inside • in black \varnothing 65 mm inside