

Hydromassage pumps

Tiper 15



Applications

For use with hydromassage systems.

Materials

Pump Body

Polypropylene

Impeller

Noryl

Motor Housing

Aluminium L-2521

Mechanical Seal

Graphite and Aluminium Oxide.

Pump foot

Polypropylene with a brass insert, threaded M10

Motor

Insulation resistance 3750 V.
Class F Insulation.
Protection IP 55.
Continuous operation.
Built-in thermal protection.

Equipment

Complete with suction and discharge connections, metric or imperial.

Options

On/off switch rear connection and level sensors via pneumatic or electrical devices.
Variable speed MV version also available.

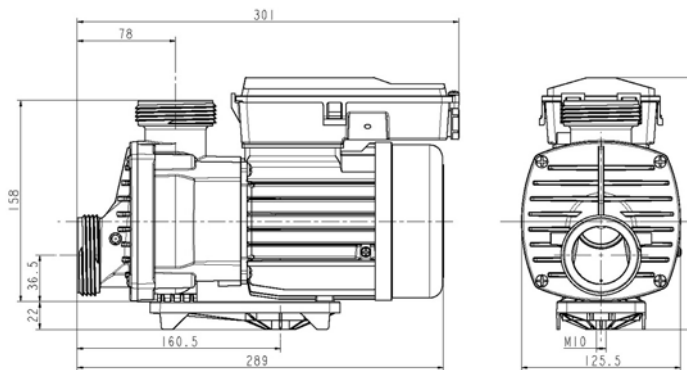
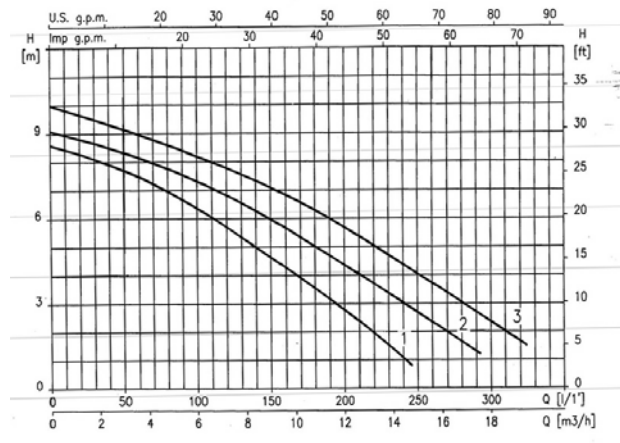

Single phase	Price	1ph 230v A	P1 (kW)	kW	HP	uF
Tiper 15 1M	184	1.70	0.36	0.18	0.25	6
Tiper 15 2M	189	2.30	0.50	0.37	0.50	10
Tiper 15 3M	205	3.00	0.70	0.55	0.75	12



See our whirlpool accessories catalogue for full details